

The GigaTech Products **TRX-10GSFP-SR-MLX-GT** is programmed to be fully compatible and functional with all intended QNAP switching devices. This SFP+ module is based on the Gigabit Ethernet IEEE 802.3az standard and is designed to be compliant with SFF-8472 SFP Multi-Source Agreement (MSA). This module is designed for copper wire cabling up to 30 meters.

Features:

- Up to 10GBd bi-directional data links
- Hot-pluggable SFP footprint
- Support 10GBase-T operation in host system
- RJ-45 Connectors
- Auto-sense MDI/MDIX
- Up to 30M over Cat 6A/7 copper cabling
- Operating temperature range
 - C-Temp: 0°C to 70°C
 - E-Temp: -10°C to 85°C
 - I-Temp: -40°C to 85°C



Compliance:

- IEEE 802.3az
- SFP MSA SFF-8472, SFF-8431
- RoHS

Applications

- 10GBd Gigabit Ethernet

Warranty:

GigaTech Branded Optical Transceivers- Lifetime Warranty

General Specifications

<i>Parameter</i>	<i>Symbol</i>	<i>Min</i>	<i>Typ</i>	<i>Max</i>	<i>Unit</i>	<i>Remarks</i>
Data Rate	<i>DR</i>		10		Gb/s	IEEE 802.3
Cable Length	<i>CL</i>		30		M	Category 6A/7 UTP
Bit Error Rate	<i>BER</i>			10 ⁻¹²		
Input Voltage	<i>V_{CC}</i>	3.13	3.3	3.47	V	
Maximum Voltage	<i>V_{MAX}</i>			4	V	Electric Power Interface
Supply Current	<i>I_S</i>		700	750	mA	Electric Power Interface
Surge Current	<i>I_{SURGE}</i>			30	mA	Hot Plug
Storage Temperature	<i>T_{STO}</i>	-40		85	°C	Ambient Temperature

High Speed Electrical Interface Host- SFP

<i>Parameter</i>	<i>Symbol</i>	<i>Min</i>	<i>Typ</i>	<i>Max</i>	<i>Unit</i>	<i>Remarks</i>
Differential Input Voltage	<i>V_{INDIFF}</i>	250		1200	mV	Differential peak-peak
Differential Output Voltage	<i>V_{OUTDIFF}</i>	350		800	mV	Differential peak-peak
Tx Input Impedance	<i>Z_{IN}</i>		50		Ohm	Single ended
Rx Output Impedance	<i>Z_{OUT}</i>		50		Ohm	Single ended

High Speed Electrical Interface Transmission Line- SFP

<i>Parameter</i>	<i>Symbol</i>	<i>Min</i>	<i>Typ</i>	<i>Max</i>	<i>Unit</i>	<i>Remarks</i>
Tx Input Impedance	<i>Z_{IN}</i>		100		Ohm	1MHz - 125MHz
Rx Output Impedance	<i>Z_{OUT}</i>		100		Ohm	1MHz - 125MHz

Low Speed Electrical Signal

<i>Parameter</i>	<i>Symbol</i>	<i>Min</i>	<i>Typ</i>	<i>Max</i>	<i>Unit</i>	<i>Remarks</i>
SFP Output Low	<i>V_{OL}</i>	0		0.5	V	Note 1
SFP Output High	<i>V_{OH}</i>	Host_ V _{CC} -0.5		Host_ V _{CC} +0.3	V	Note 1
SFP Input Low	<i>V_{IL}</i>	0		0.8	V	Note 1
SFP Input High	<i>I_{HL}</i>	2		V _{CC} +0.3	V	Note 1

Note 1: External 4.7-10k ohm pull-up resistor required

Dimensions

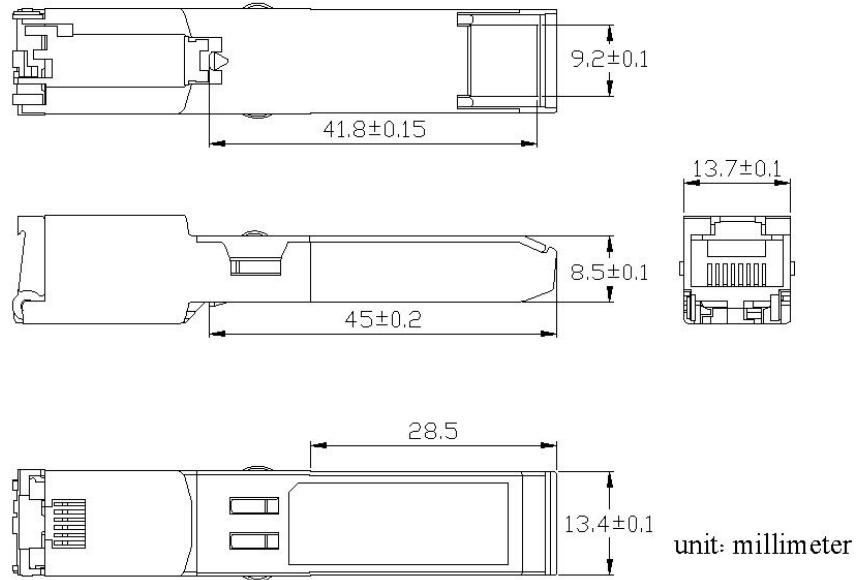

ALL DIMENSIONS ARE ± 0.2 mm UNLESS OTHERWISE SPECIFIED

UNIT: mm

PCB Layout Recommendation

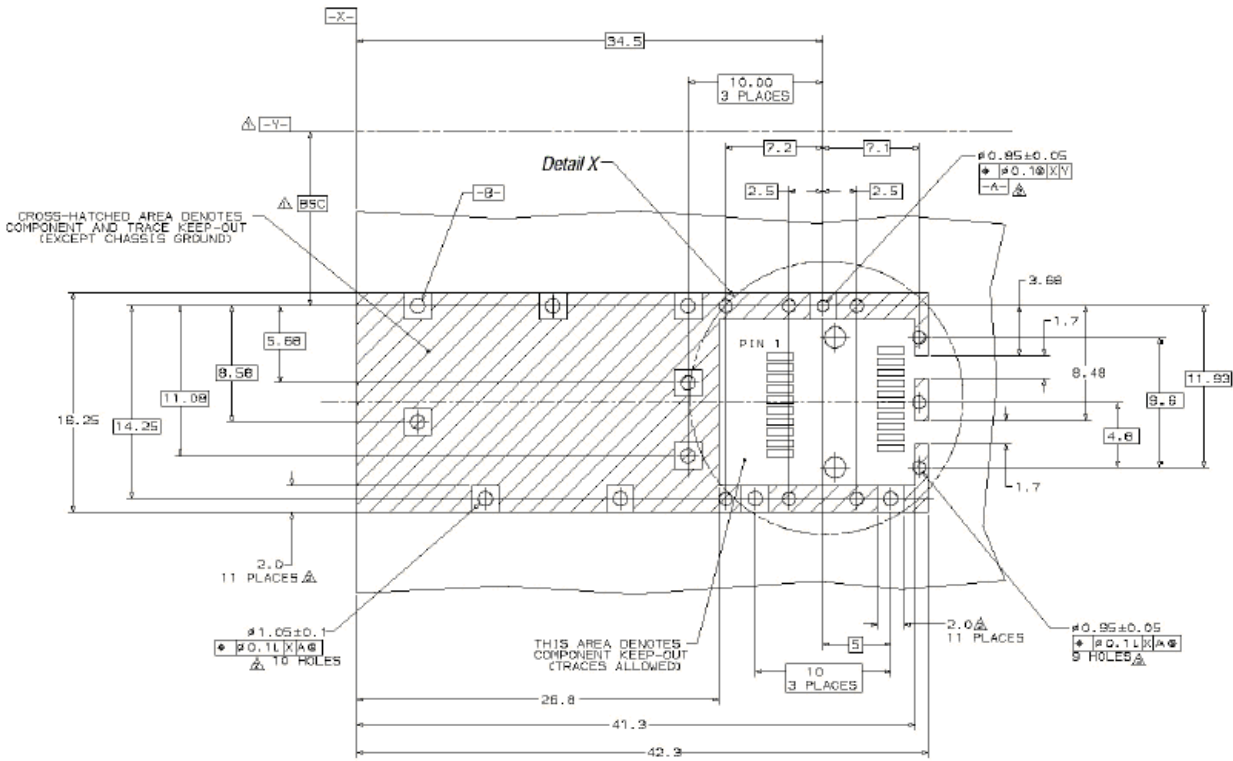

- Datum and Basic Dimension Established by Customer
- Pads and Vias are Chassis Ground, 11 Places
- Through Holes are Unplated

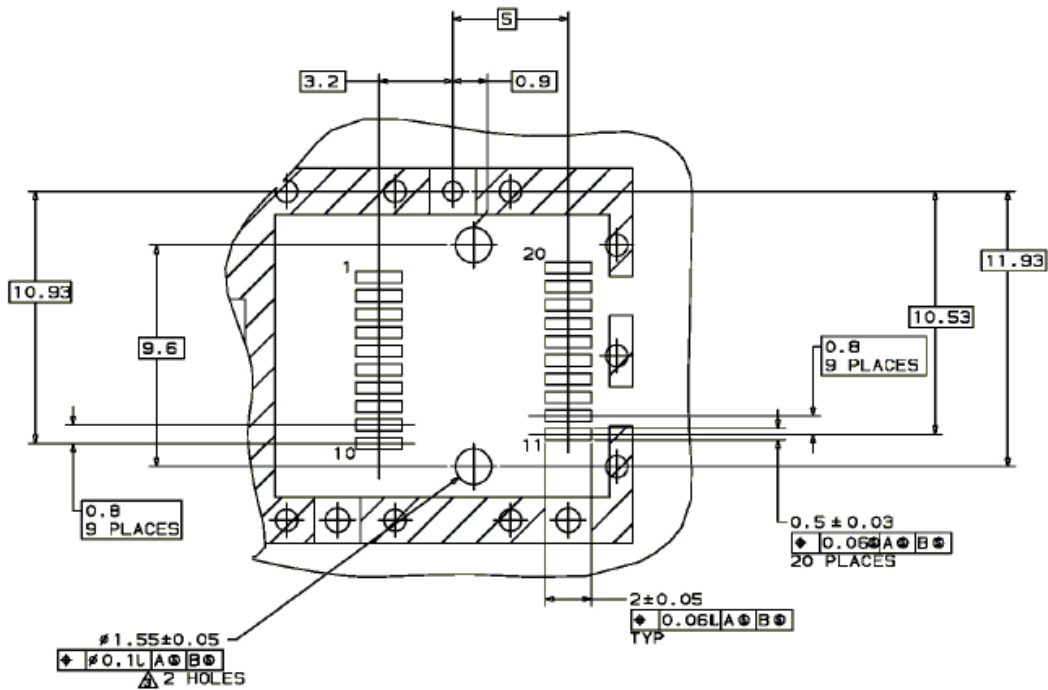

Electrical Pad Layout

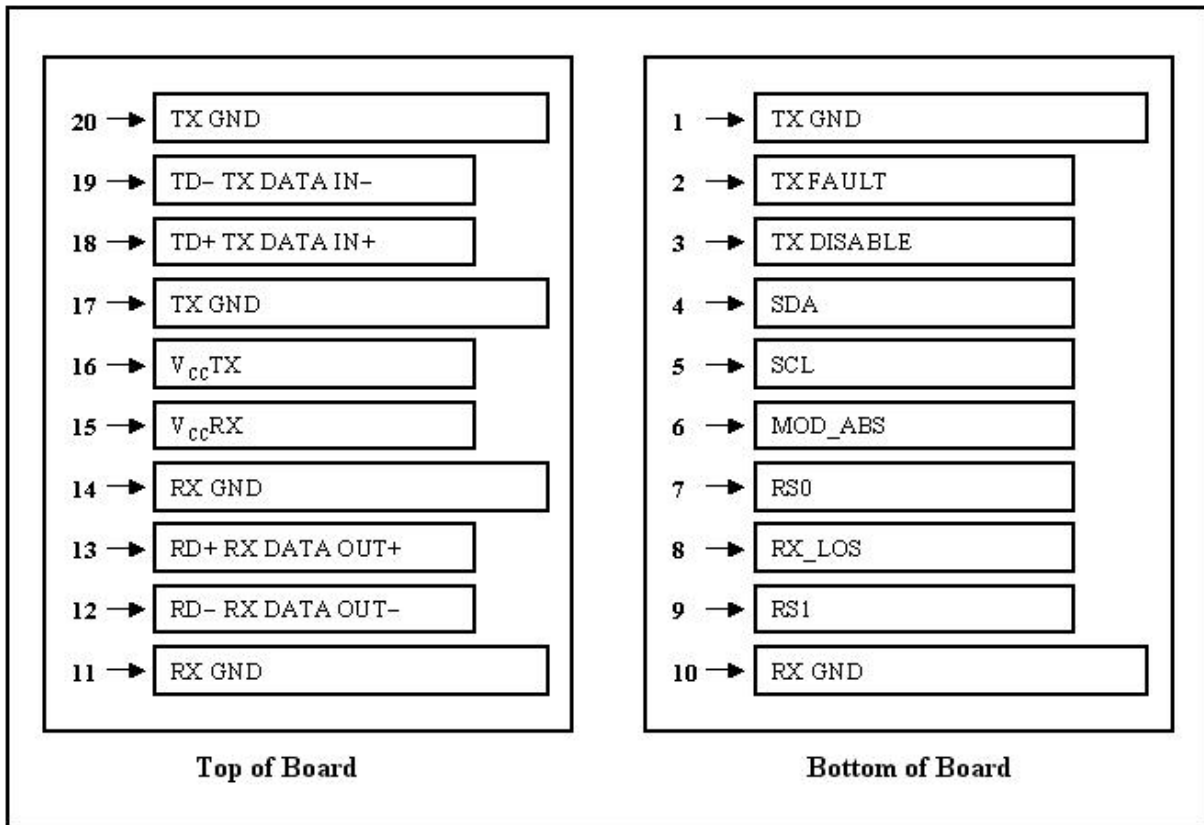
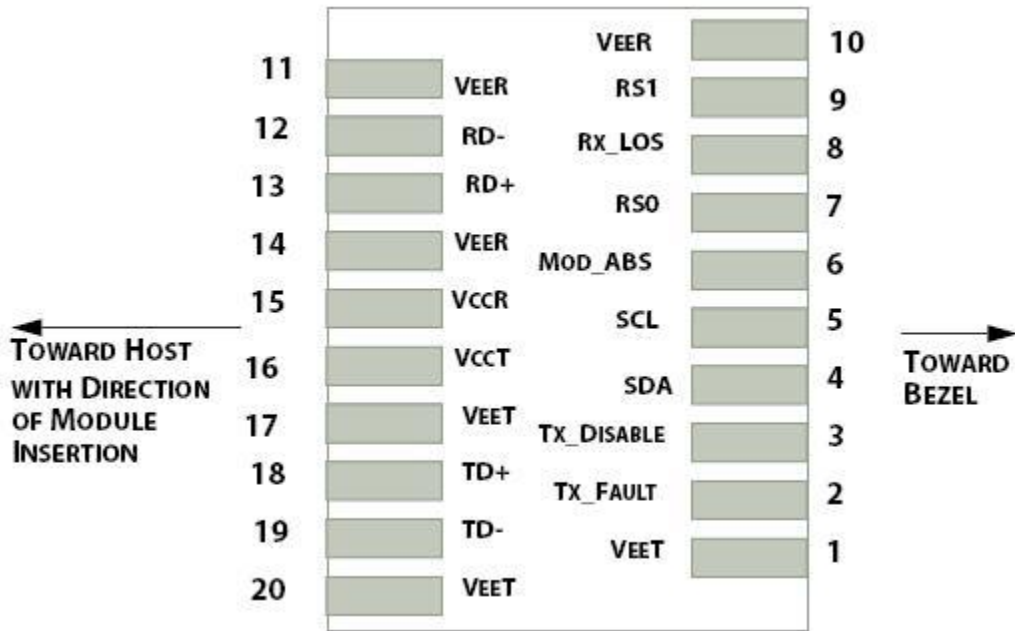

Pin Assignment

PIN #	Symbol	Description	Remarks
1	VEET	Transmitter ground (common with receiver ground)	Circuit ground is isolated from chassis ground
2	TFAULT	Transmitter Fault	
3	TDIS	Transmitter Disable. Laser output disable on high or open	Disabled: TDIS>2V or open Enabled: TDIS<0.8V
4	MOD_DEF (2)	Module Definition 2. Data Line for Serial ID	Should Be pulled up with 4.7k – 10k ohm on host board to a voltage between 2V and 3.6V
5	MOD_DEF (1)	Module Definition 1. Data Line for Serial ID	
6	MOD_DEF (0)	Module Definition 0. Data Line for Serial ID	
7	RS	No Connection required	
8	LOS	Loss of Signal indication	Not Supported
9	VEER	Receiver ground (common with transmitter ground)	Circuit ground is isolated from chassis ground
10	VEER	Receiver ground (common with transmitter ground)	
11	VEER	Receiver ground (common with transmitter ground)	
12	RD-	Receiver Inverted DATA out. AC coupled	
13	RD+	Receiver Non-inverted DATA out. AC coupled	
14	VEER	Receiver ground (common with transmitter ground)	Circuit ground is isolated from chassis ground
15	VCCR	Receiver power supply	
16	VCCT	Transmitter power supply	
17	VEET	Transmitter ground (common with receiver ground)	Circuit ground is connected to chassis ground
18	TD+	Transmitter Non-inverted DATA out. AC coupled	
19	TD-	Transmitter Inverted DATA out. AC coupled	
20	VEET	Transmitter ground (common with receiver ground)	Circuit ground is connected to chassis ground

References

1. IEEE standard 802.3. IEEE Standard Department, 2005.
2. Small Form Factor Pluggable (SFP) Transceiver Multi-Source Agreement (MSA), September 2000.